

# ELEMENT<sup>®</sup>



## HYPR-7

HYBRID BALLISTIC RIFLESCOPE

### OWNER'S MANUAL

# Index:

|     |                                 |    |
|-----|---------------------------------|----|
| 1)  | Introduction & Package Contents | 1  |
| 2)  | Mounting your Riflescope        | 2  |
|     | -Mount Information              |    |
|     | -Alignment & Mounting Process   |    |
| 3)  | Battery Installation            | 4  |
| 4)  | Diopter & Parallax              | 6  |
| 5)  | Connectivity                    | 7  |
| 6)  | Application Setup               | 8  |
| 7)  | Pairing your Device             | 10 |
| 8)  | Setting Up Your Riflescope      | 12 |
| 9)  | Creating a Ballistic Profile    | 14 |
| 10) | Zeroing                         | 15 |
| 11) | Using Ballistic Features        | 20 |
| 12) | Display Orientation             | 21 |
| 13) | Reticles                        | 23 |
| 14) | Using External Rangefinders     | 26 |
| 15) | Warranty                        | 27 |

## THE NEXT GENERATION: **HYBRID PRECISION RIFLESCOPE**

You are the new owner of one of the most advanced shooting systems on earth. The HYPR-7 combines the superior clarity and resolution of an analog optical system with the flexibility of a digital reticle, with technology far ahead of its time enabling you to reach further, faster. With a variety of on-board sensors and a powerful ballistic chip, you no longer have to process information & input firing solutions yourself - It is all done for you in a fraction of a second. And it gets even better... With the ability to integrate with other devices, you'll be able to create a shooting system according to your requirements and experience the full potential of the digital system, all while enjoying a crisp image through HD glass.

### WHAT'S IN THE BOX?

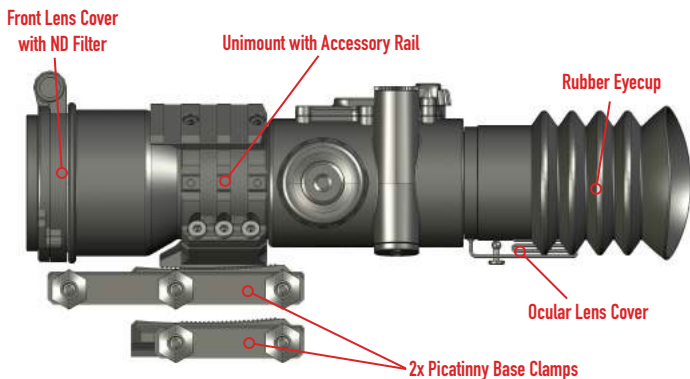

Your rifle system is only as good as its weakest point, and so mounting of a riflescope is a very critical process that requires time and precision. If you feel uncomfortable doing this yourself we suggest visiting a gunsmith, as incorrect mounting can cause many issues down the line.

### Mount Information: We've Made it Easy!

The Hybrid Riflescope supplied with a set of tilt-adjustable mounts.

The adjustable mounts allow the shooter to determine the tilt angle of the scope, which will keep the reticle centred in the optical system and ensure that you never run out of elevation travel. The mount is marked in MOA (Minutes of Angle)

The scope comes with the mount pre-installed, and set at "0" tilt. This adjustment is important as it allows you to roughly align your riflescope with your target and center your "canvas" on which the reticle itself will be projected.

### To Adjust Tilt on the Mount:

- Loosen the screws (Fig.1, Pos.A) just enough to allow the upper mount to be lifted and repositioned (Fig.2, B,C)
- Once you have the desired tilt, tighten the two screws back in place.

Do not use excessive force when tightening the screws, and be careful not to strip the thread. The torque on the screws should be about 2 ft.lb (2.7 Nm), **NEVER APPLY MORE THAN 5 ft.lb (6.8 Nm) OF TORQUE** as this will damage the mount.

### Mounting the Base to a Picatinny Rail:

Loosen the Base Nuts and fit the mount to the rail, ensuring that the cross bolts fit correctly in the rail slots. Shoulder the rifle to check whether eye relief is correct, and adjust mount position accordingly. Torque the nuts down to **50 in.lbs (5.7Nm)** using a 13mm or 1/2" Socket.

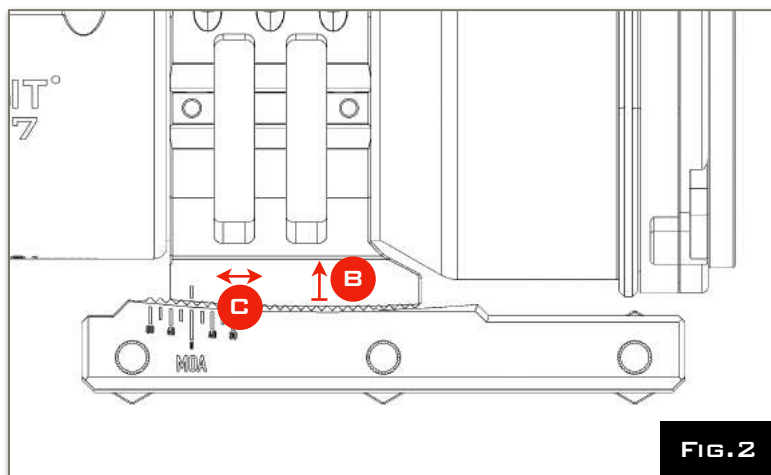
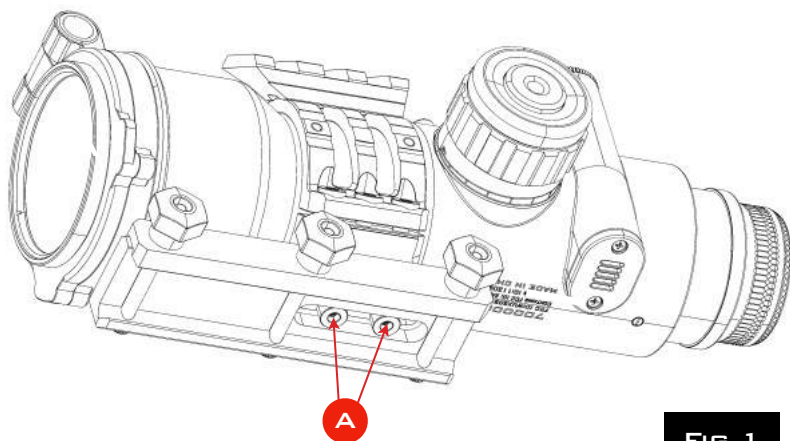

### Torquing down the Ring Screws:

- 1) When fitting the riflescope to your rifle, ensure that the mount is firmly attached to the rifle BEFORE you tighten the top screws down.
- 2) Use a bubble level on the picatinny rail to ensure that the riflescope is level before using the built-in level inside the display (see page 21) to level the scope. A canted reticle will cause point of impact drift to the left or right, and affect accuracy.
- 3) If the scope needs to be levelled, loosen the ring screws and adjust the scope position until cant error is removed. Once you are happy with the position of your riflescope, begin to torque down your rings in a criss-cross pattern, moving between screws and turning small amounts at a time. **Use a torque of 1.2-1.5 Nm (10.6-13.3 in-lbs) for the ring screws.**

## BATTERY INSTALLATION

This unit requires one 1.5v AAA Battery (LR03) for operation. These batteries are very common and can be purchased almost anywhere. Rechargeable NiCd or NiMH batteries of the same size may also be used (KR03 or HR03). **DO NOT USE BATTERIES WITH NOMINAL VOLTAGE OVER 1.5V.**

### Installation

- Unscrew the Battery Compartment Cover (Fig.3, Pos.A)
- Insert a AAA Battery, **positive** side down (Fig.3, Pos.B)
- Screw the battery compartment cover back on

### Switching the unit On/Off

Once the battery is installed, the scope can be switched on by pressing the main button on top of the scope (Fig.3, Pos.C). To switch the scope off, hold the main button (Fig.3, Pos.C) down for over a second. Once the button is released, the scope will switch off.

## Battery Life

The scope features ultra low power consumption, a fresh AAA battery from a reputable supplier typically lasts for **over 70 hours** of continuous scope operation, and almost indefinitely when the scope is switched off. The scope can be configured to automatically switch off after a timeout. This can be set in the iOS or Android application - See pg.12, Fig.9

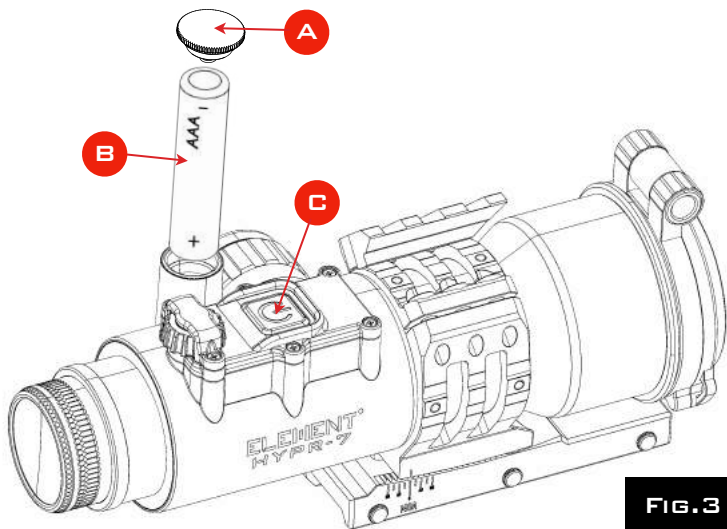

FIG.3

## Eyepiece - Focusing the Reticle

Everybody's eye is different, and the ocular lens will need to be adjusted for your eye in order for the reticle to appear in focus. To do this, point the rifle scope towards a blank or featureless background (i.e. a white wall or blue sky) and turn the ocular adjustment ring clockwise and counter-clockwise until the reticle appears in optimum focus (Fig.4, Pos.A)

## Parallax Knob - Focusing the Target

A well-adjusted parallax is crucial for optimum precision, as it places the reticle in the exact same focal plane as the target and "fixes it in place", eliminating the possibility of parallax error. And, of course, it allows you to see your target clearly. To adjust parallax, rotate the parallax knob (Fig.4, Pos.B) until your target is in focus. The parallax wheel is not marked externally, however your focus distance can be programmed to project within the unit's display.

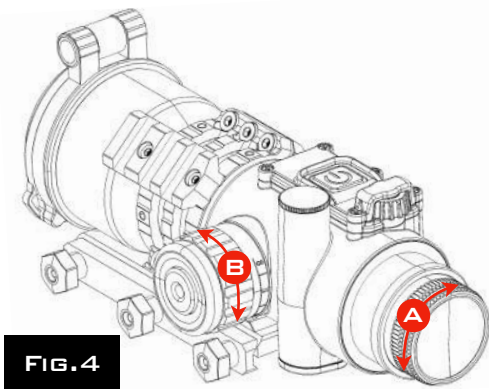

**FIG. 4**

Optionally, you can install supplied lens caps and/or the rubber eyecup.

The rear lens cap can be put on top of the battery cover when the scope is in use.

The front lens cap has an integrated optical density filter. Flipping the cap open keeps the lens completely unobstructed, while closing the cap down reduces the amount of light reaching the scope and makes the reticle more visible in bright conditions.



The HYPR-7 Riflescope contains a computer that needs to have a profile loaded with your ballistic information in order to make accurate calculations. This means installing the accompanying **ELEMENT BALLISTICS** iOS or Android application on your smartphone, which acts as an interface and allows you to quickly and easily enter all information required. You can search for “Element Ballistics” on the Apple App Store or Google Play.

Once the application is launched, it will ask your permission to connect to Bluetooth™ devices and use location services. Location services are required to connect to Bluetooth™ Low Energy devices. We do not track your location and your personal information is never passed on. Please, grant these permissions to be able to connect to the scope.

Internet Connectivity & Location Services also allow for weather updates at your location, which can supply the temperature, humidity & barometric pressure data needed for precise ballistic calculations. This data can also be measured by the HYPR-7's onboard sensors.

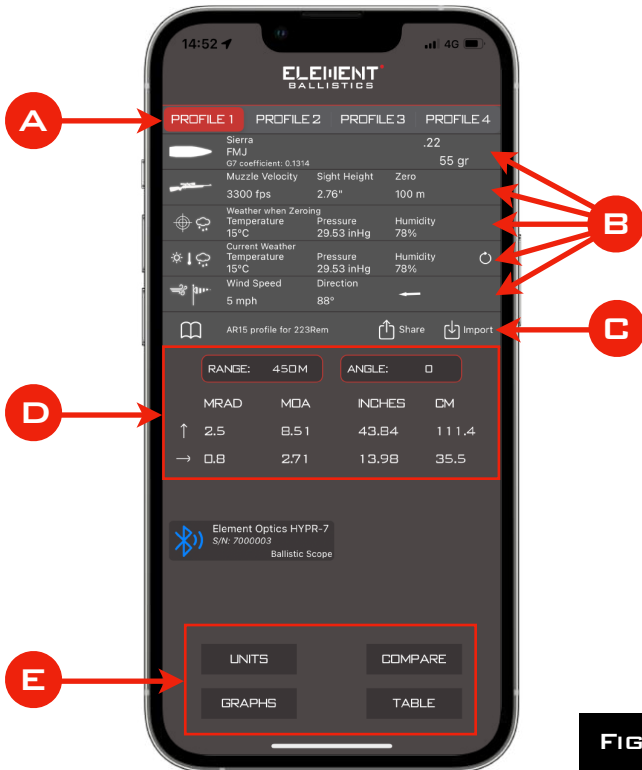

FIG. 5

The diagram above shows the main view of the ELEMENT BALLISTICS app.

Four ballistic profiles (A) can be edited independently.  
 Grey areas (B) can be tapped to configure your ballistic parameters.  
 Firing solutions are displayed at (D) for use with traditional riflescopes  
 Ballistic table (D) gives your shooting corrections for different distances.  
 (E) Unit Preferences & Trajectory Information (graphs & tables)

The main screen of the Element Ballistics application has the following control areas (Fig.5):

A) Tabs for four separate ballistic profiles. You can edit these profiles independently from each other. You can dedicate different profiles to different types of ammunition you are using. Standard profiles are: 1) AR-15, 2) .308 Win, 3) .22LR, 4) Airgun

B) These are used to set different parameters of your ballistic profile. Tapping these areas opens the corresponding configuration screen. You need to select the type of a bullet that you are using, set its muzzle velocity, zeroing range, and so on. Weather parameters, such as temperature and barometric pressure, can be set manually, requested from an Internet weather service or obtained from the HYPR-7's internal sensors. Wind speed and direction are also set in this area.

C) Profiles can be named here and exported/imported. This allows you to share profiles with friends over Whatsapp, Email, Airdrop, etc. or simply save additional profiles for future use.

D) A Firing Solution for any device can be obtained by entering a distance and angle here. The app calculates elevation and windage corrections for the selected profile in MRAD, MOA, cm and inches.

E) Unit preferences can be set by selecting the "units" tab. This sets preferences for both the app and the HYPR-7. Additional resources like graphs, tables and other data can also be found here.

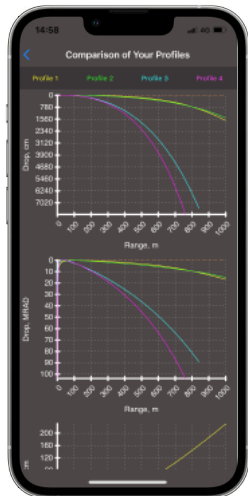

If you switch on the HYPR-7 while running the application (make sure Bluetooth is enabled on your phone and permissions are granted to the application), the scope will be discovered and a card will appear at the bottom of the phone's screen (Fig.6).



**FIG.6**

Tap this card to connect to the scope.

If it is the very first time you are connecting to the scope, device pairing will be required. The phone will display the system standard pairing request window (Fig.7). This window will ask to enter the pairing code.

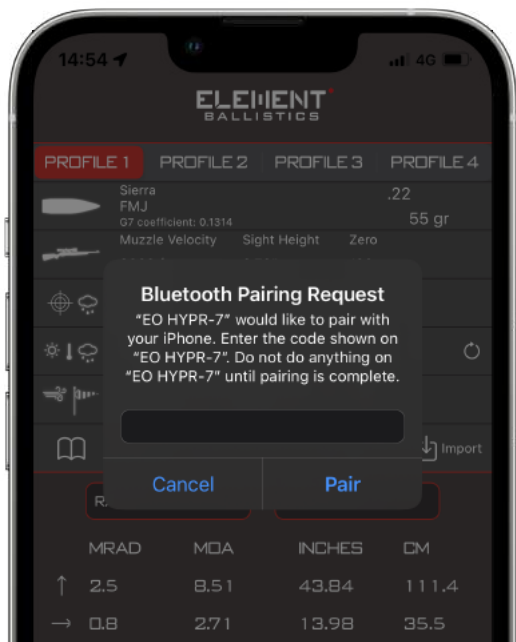

**FIG.7**

To find the pairing code you need to **look into the scope**. The reticle will display six random digits to be used with your phone (Fig.8). Upon pairing request the scope displays the code to be used on your phone.

Once correct code is entered, the phone will remember how to connect to your scope in the future, and will not ask to pair again.

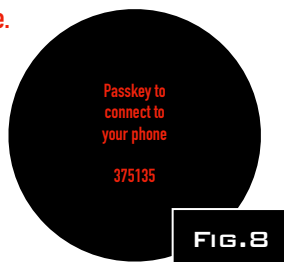

Every time the scope is discovered by your phone, you can connect to tapping the discovery card (Fig.6). To disconnect from the scope, tap the “disconnect” button.

When the scope is connected, the scope configuration screen (Fig.9) will appear.

Once the HYPR-7 Riflescope has been paired your smartphone and a profile loaded, the profile will be stored on the HYPR-7's chip and CAN be used even once the smartphone is disconnected. Your smartphone only needs to be connected when a new profile has to be transferred.

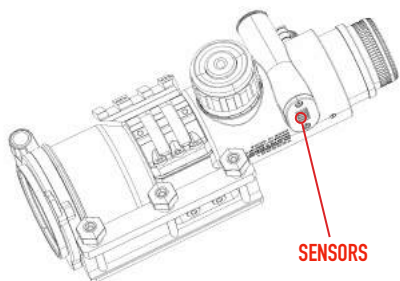

The HYPR-7 has integrated sensors, including an inclinometer (angle), barometer (pressure), thermometer (temperature) and hygrometer (humidity). There is no need to reconnect to the app to update these parameters!

Now that you're paired, you will be able to change multiple settings to configure the scope to your liking. The Scope Configuration Screen (Fig.9) has the following sections (as labeled below):



**FIG.9**

A) Scope automatic power down timeout. If “Never” option is selected, the scope can only be switched off by holding down the top button. Any other option sets an inactivity timer for automatic power down. Using any control on the scope will reset this timer. Only if there is no user input for a set amount of time, the scope will power down.

B) The source of shot inclination when using a Bluetooth™ rangefinder can be selected in this section. If “Rangefinder” option is selected, then the inclination measured by the external rangefinder will be used when computing the trajectory. If the “Scope” option is selected, then rangefinder angle measurement will be ignored and the inclination measured by the scope will be used instead.

C) A number of reticle options can be selected in this section – See more on page 23. The last option is the user-designed reticle. You can supply and upload your own reticle to the scope using a separate button labelled (D) in Fig.9

D) Pressing this button will take you to a separate screen for uploading a custom reticle.

E) This section allows you to choose how to display calculated ballistic corrections. Option “Aiming Dot” displays a small blinking dot on your reticle corresponding to the calculated point of impact due to bullet trajectory. Option “Move Reticle” moves the whole reticle in a way that it is centred at the calculated point of impact.

F) “Zeroing” button takes you to a separate screen used for setting up and zeroing your scope. This will be covered in detail in the next section of this manual.

G) “Upload Profiles” button uploads all four profiles set in the Element Ballistics app to your scope. Once uploaded, these profiles can be used in the scope without connection to your phone.

H) “Disconnect” button closes down the configuration screen.

**Uploading custom reticles and ballistic profiles has to be confirmed through additional steps, while the rest of the options take effect immediately.**

**Before proceeding to zeroing your scope, you need to decide what ammunition you are going to use, measure the sight’s height over the bore of your barrel, and configure the first ballistic profile to match your ammunition selection.**

Upload profiles to your scope before zeroing. In the configuration screen (Fig.9), press the “Upload Profiles” button (Pos.6).

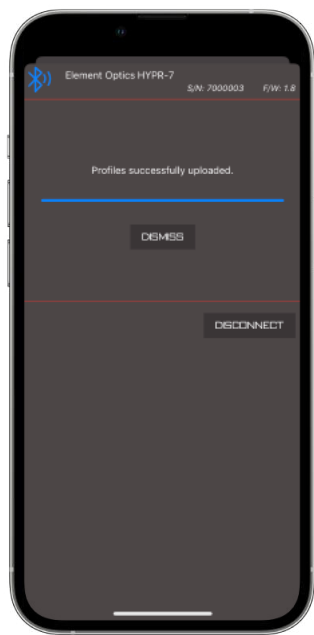

**FIG. 10**

Once the profiles are uploaded (the progress bar is at 100%, and the line above it states “Profiles successfully uploaded”, see Fig.10), you can press the “Dismiss” button. If there is any problem with uploading profiles, try uploading again.

Once profiles are uploaded, the progress bar will be at the rightmost position, and the message will state “Profiles successfully uploaded”. If there is any error when uploading the profiles, the scope will discard partial data, and keep old profiles in place.

With your profiles uploaded, you are now independent of your smartphone. The HYPR-7 will make real-time calculations based on the loaded profile, and take incline & weather conditions into account (with onboard sensors) while distance & windage information can be input via external bluetooth devices or manual input (parallax knob & top dial). The process of obtaining an accurate firing solution just got a whole lot faster!

With your profile installed, you now need to zero your riflescope. Zeroing your scope, or “sighting in”, means aligning the sights on your rifle with the point where the bullet strikes at a certain distance.

Before you begin, set the scope to use the desired ballistic profile (most likely Profile 1 in the very first instance), and the range is set to the zeroing range of that profile. The reticle should look similar to Fig.11 below.



This is a basic view through the scope. Position (A) indicates your current source of shooting range data. "ZR" means that the range is set to the zeroing range in your current ballistic profile. Position (B) displays which ballistic profile is currently in use. "P1" corresponds to the first ballistic profile.

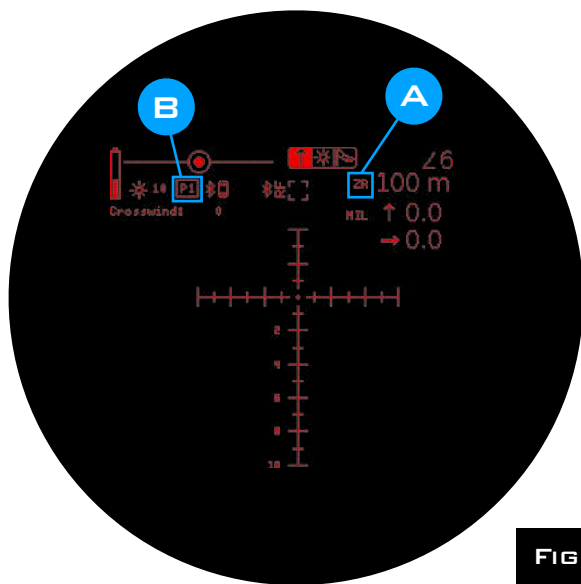
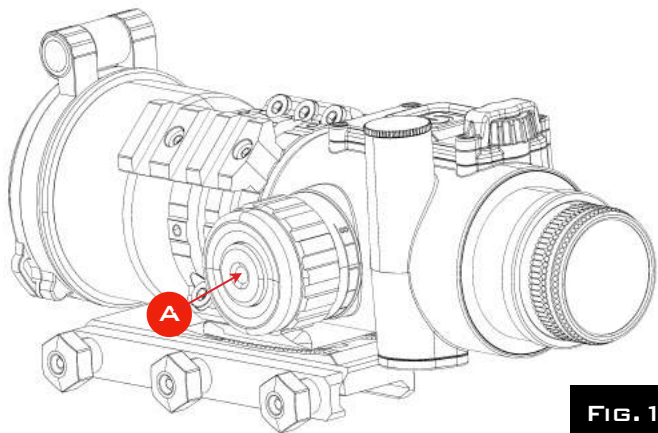

FIG. 1 1

If the range source (Fig.11, Pos.A) is anything else but "ZR", you need to reset it to the zeroing range. You can do it by pressing and holding the central button on the focusing turret (see Fig.12).

Before zeroing the scope, make sure your rifle is in good order, the barrel is cleaned, and you selected appropriate ammunition to use.

Zeroing will involve shooting with your rifle and adjusting the scope to point at the bullet's point of impact. **ALWAYS FOLLOW APPROPRIATE GUN SAFETY AND SAFE SHOOTING PROCEDURES.**

**FIG. 12**

### **STEP 1**

The first thing you must do is to get your rifle “on paper”. In order to do this, you must get your barrel and scope in rough alignment. A collimator or laser boresighter will enable you to do it quickly, and these devices are the only option for actions (semi-autos, levers, or pumps) where it is not possible to look down the barrel from the breech.

Before you begin aligning your scope, open the Element Ballistics app and connect to your scope as described earlier. Open the scope configuration screen (Fig.9) and tap on the zeroing button (Fig.9, Pos.F). Zeroing procedure window will open (Fig.13). Tap on the “Centre Reticle” button to reset any previous zeroing settings.

With bolt actions, rough alignment can be achieved by boresighting. Remove the bolt, or in a single-shot, open the action and set the rifle in a solid, steady rest. Put up a target at short range – 25 or 50 yards. We will not be shooting at this target, only aligning with it. A bull's eye target is probably best for this because it is easier to align the round target with a round view through your barrel. Line up your barrel with the target, make sure it is steady, and then look through your scope. Use mount adjustments until you see the same “picture” as through your barrel.

## STEP 2

Now it's time to shoot. Make sure it can be done safely.

Make sure there is reliable backstop behind your target. It is worth starting with a large target at a short range to get initial zero, as sometimes boresighting may be way off.

Fire a shot at your target. Remember, the initial shots may be way off.

Adjust the mount of the scope to align the centre of the reticle just above the point of bullet impact. This step allows your reticle canvas to remain close to the optical centre of the riflescope, giving you more room for vertical adjustment.

## STEP 3

Move your target to the final zeroing range as set in your ballistic profile. The target should have a clear point of aim. Make sure it is safe to commence live fire. Rifle should be placed on a steady rest. Check scope's reticle to make sure correct profile is selected, and distance source is set to “ZR” (Fig.11). Aim and fire a shot.

Now we will move the reticle and place it on the point of bullet impact. Open the Element Ballistics app, connect to your scope, go to configuration, and then to the zeroing screen as shown in Fig.13. Tap on “Move Reticle” button, and a new screen will open as depicted in Fig.14. Tapping “Up”, “Down”, “Left”, or “Right” buttons will move two reference lines in your reticle (Fig.15). Align the main reticle with the aiming point you were using when firing the shot, and move these reference lines to intersect at the point of bullet impact.

Tap “Confirm” to finish adjusting your reticle. It will now be permanently placed to coincide with the point of bullet impact. If it is safe to do so, shoot a group of 3–5 shots and readjust the reticle to be in the centre of the group using the same procedure.

**NOTE:** The zeroing procedure can also be performed without the app. Press the power button (Fig.16, Pos.D) to access the HYPR-7’s main menu, and select “Zeroing”

#### **STEP 4**

Place your rifle in a steady rest and use a bubble level or an electronic level placed on top of the scope (battery cap can provide a flat platform) to check level. Adjust the rest to bring the scope to a perfectly levelled position.

Once you are certain that the scope is level, open the Element Ballistics app and connect to your scope as described earlier. Open the scope configuration screen (Fig.9) and tap on the zeroing button (Fig.9 Pos.F). Finally, tap on “Reset Levels” and then confirm to calibrate your scope.

**Now your scope is zeroed, calibrated and ready to be used.**



FIG. 1 3



FIG. 1 4

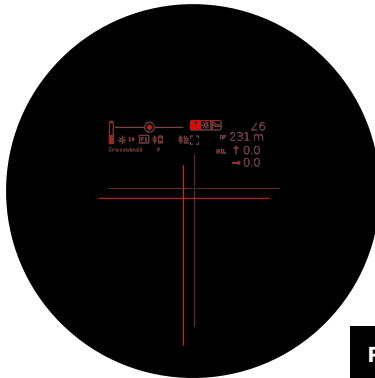

FIG. 1 5

One of the most important features of the HYPR-7 is the built-in ballistic computer. Once an appropriate ballistic profile is created and uploaded to the scope as described earlier in this manual, bullet trajectory can be calculated completely autonomously by the scope without connection to the phone.

The main input required for the computation is the distance to the target.

There are four main ways to input that distance:

- 1) Pressing and holding the mode button (Fig.16, Pos.A) on the focusing turret sets current distance to the zeroing distance for the current profile.
- 2) Turning the parallax wheel (Fig.16, Pos.B) provides a distance estimate. This estimate is only reliable to about 100 yards.
- 3) The distance can be entered manually by turning a wheel at the top of the scope (Fig.16, Pos C). The Input Mode needs to be on "Elevation" (left icon, Fig.17 Pos.F) for this function.
- 4) The distance can be obtained from a compatible laser rangefinder (see pg. 22)

When the distance is changed, bullet trajectory will be recalculated, reticle will be adjusted to the estimated point of impact, and calculated corrections will be displayed at the top of the reticle.

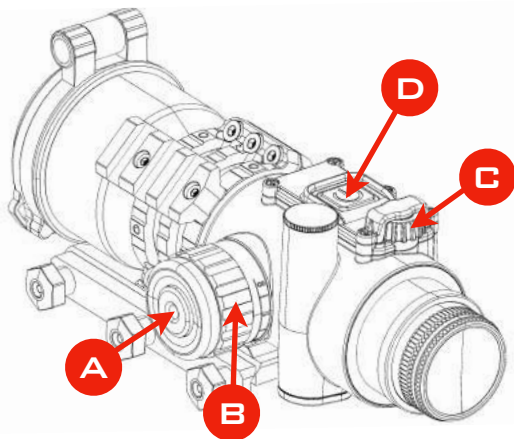

**FIG. 1 6**

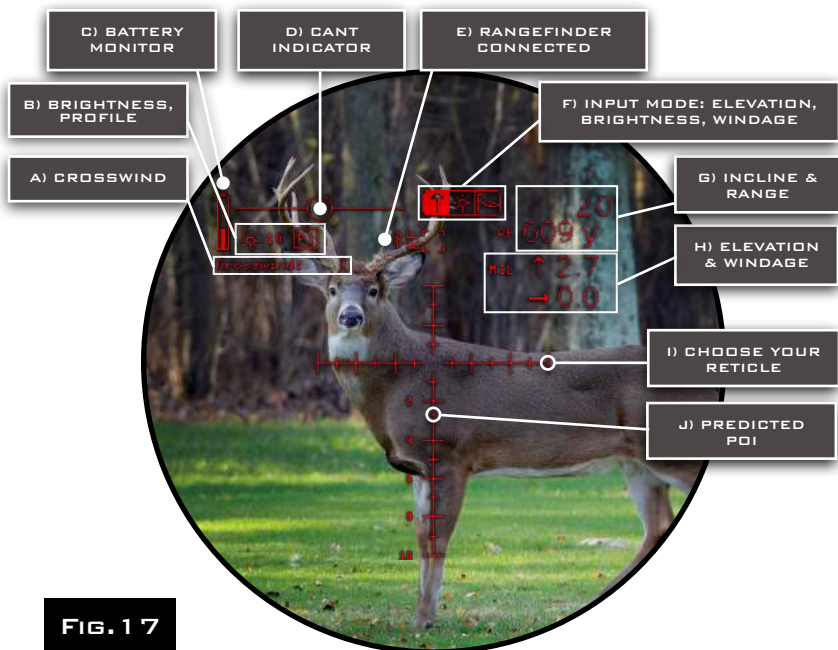

**FIG. 17**

- A) **CROSSWIND:** Can be dialled in by pressing the mode button (Fig.16, Pos.A) to select the “windage” input mode (Fig.17, Pos.F, icon 3) and turning the input dial (Fig.16, Pos.C) clockwise (right wind) or anticlockwise (left wind).
- B) **BRIGHTNESS & PROFILE:** Display Brightness has 15 settings and can be adjusted by pressing the mode button (Fig.16, Pos.A) to select brightness input mode (Fig.17, Pos.F, icon 2) and then using the input dial (Fig.16, Pos.C) to turn up or down. Profile icon indicates the profile in use (P1, P2, P3 or P4). These can be selected within the scope by pressing the power button (Fig.16, Pos.D), selecting “PROFILE” and using the input dial to select profile number.

- C) **BATTERY MONITOR:** Displays battery level. When battery gets extremely low, the scope will go into "Emergency Mode" which switches off the ballistic calculator but still allows you to use the reticle. This will give you a few hours to change the battery.
- D) **CANT INDICATOR:** Indicates whether the scope is level or not. When level, a dot will appear in the centre circle.
- E) **RANGEFINDER CONNECTED:** This icon appears when a rangefinder is connected by bluetooth. The square is an "aiming point" in which you can place the beam of a range finding module. Having this aim point allows you to range small targets precisely.
- F) **INPUT MODE:** Tells you which parameter you are setting with the input dial (Fig.16, Pos.C). Pressing the mode button (Fig.16, Pos.A) cycles through the three modes: Elevation, Brightness and Windage.
- G) **INCLINE & RANGE:** The two most important input parameters for the ballistic calculator. The incline is measured automatically by the inclinometer, and the range is inputted using one of the methods shown on Page 20. The input source is shown as "ZR", "MAN", "RF" or "FOCUS".
- H) **ELEVATION & WINDAGE:** Shows your firing solution for the specific profile and distance selected. Units are shown as "MIL", "MOA", "CM", "INCH" or "CLICKS". This is calculated automatically.
- I) **RETICLE:** The reticle can be chosen within the app. See page 23 for more details.
- J) **PREDICTED POINT OF IMPACT:** The HYPR-7 calculates your bullet drop & drift, and shows you where your bullet will land. You can choose whether you want your entire reticle to move, or whether you want a flashing aiming dot to be projected on top of the reticle. This can be set in the configuration screen on the app (Fig.9, Pos.E)



The HYPR-7's digital display allows for endless reticle designs. We offer 4 standard reticles, one smart reticle, and the option of designing your own.

### STANDARD RETICLES

- The "Hash" reticles are based on the Element APR family of reticles and provide numbered hold points. Units are automatically set to MRAD or MOA based on your preferences.
- The "Mil-Dot" reticle is a traditional, familiar military design.
- The "Simple Crosshair" is designed for those who don't want to think in angular units and prefer to rely on the scope's ability to shift your aim point. This reticle makes it easier for you to spot the aiming dot projected by the ballistic calculator.

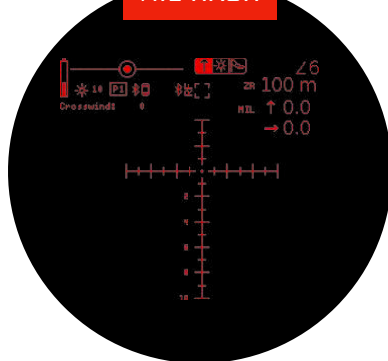
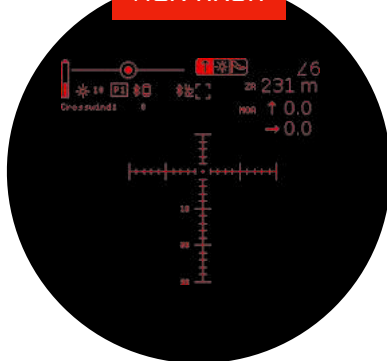
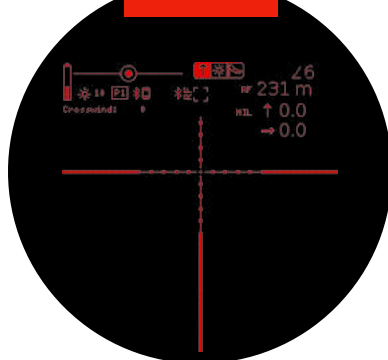
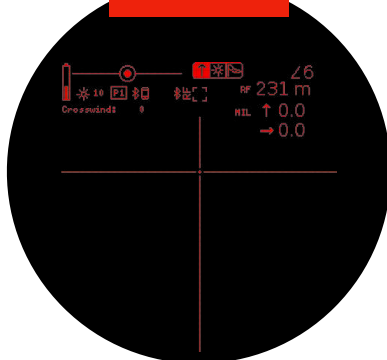
**MIL HASH****MOA HASH****MIL DOT****CROSSHAIR**

## SMART RETICLE: LIVE BDC

The LIVE BDC reticle showcases the potential of the HYPR-7. The inherent problem with every other BDC reticle on the market is that it is fixed; it cannot adjust to changing conditions and cannot be made to perfectly match your bullet's trajectory. This fixes that problem.

The HYPR-7 creates a BDC reticle based on your exact ballistic profile, with distance values chosen by you, and wind holds for those distances. Not only does this reticle adapt to changing atmospheric conditions throughout the day (i.e. will compensate as the air density changes), but it also recalculates and stretches/compresses as your incline angle changes.

This reticle is best used when you don't have time to range a target, or don't want to connect an external rangefinder. Simply hold and shoot - a total game changer!

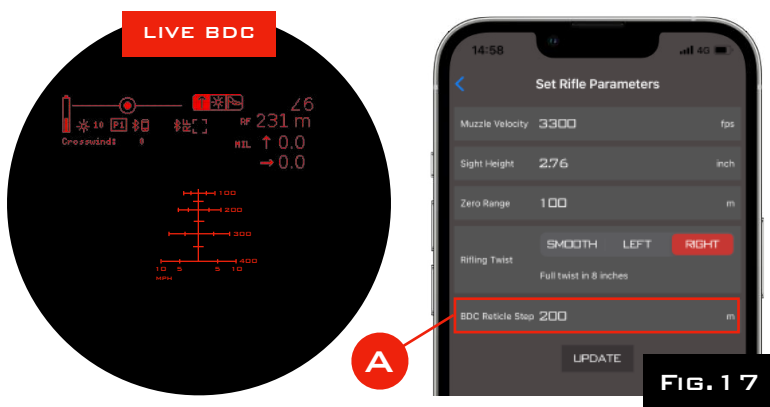

## SETTING RETICLE STEP DISTANCE

You will need to manually enter the distances you want projected in the rifle parameters menu of each ballistic profile (Fig.17, Pos.A). The reason this needs to be manual is to ensure good spacing between each hold line. If the distances are too close together, the lines & numbers will overlap each other and won't be legible. Slow projectiles like airgun pellets and crossbow bolts will need steps closer together (20m, for example), while flat-shooting centerfires will need larger steps (100-200m/yds). These steps are measured from your zero distance - i.e. if you are zeroed at 110m and have your step set to 100m, your hashes will project at 210, 310, etc.

## DRAWING YOUR OWN RETICLE

The HYPR-7 System allows you to draw & upload your own reticle.

To upload custom reticles, connect to the HYPR-7 using the Element Ballistics app, enter the configuration window, and select the 5th option, clicking “Set your Own” (Fig.9, Pos.C&D).

A window will open asking you to select a custom reticle design (Fig.18). To add a new design, click “Add New”, and a window with open, allowing you to upload your design.



**FIG. 18**

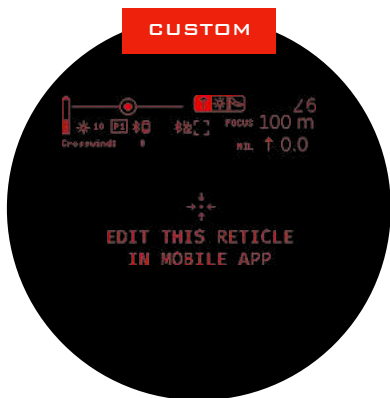

You can load your own reticle from your documents or iCloud folders. **The reticle must be an image 301 pixels wide, 401 pixels tall, and must be white on black background.** Aiming center should be exactly in the middle at column 151 and row 201. One pixel approximately corresponds to 0.308 MOA (18 seconds of angle)

Once you have added your design, hit “Upload” (Fig. 18), and the reticle will be sent to your HYPR-7.

The HYPR-7's Bluetooth™ connectivity allows for intelligent connection to an external rangefinder. This speeds up the process of engaging a target significantly by automatically entering the range into the system.

We've designed a small Rangefinding Module (sold separately) that mounts to the accessory rail on the HYPR-7. The rangefinder has a gimbal mount which allows it to be aligned precisely with an aim point in the HYPR-7 display (Fig.19, Pos.A) and tightened in this position.

## ALIGNING THE RANGEFINDER BEAM

- 1) Connect the Rangefinding Module to the Accessory rail on the HYPR-7 Unimount OR an external mounting point on your rifle. It is advised to use the mount position on the HYPR-7 to keep the rangefinder and scope as close to each other as possible - This will help with beam alignment.
- 2) Loosen the gimbal clamp on the range finding module until you are able to move the module within the clamp.
- 3) Switching on the rangefinder will automatically connect it with the scope, and the "RF" Icon will appear on the HYPR-7 display: 
- 4) Pressing the "MODE" button on the RF module will activate a visible laser. Align the module until the beam lands within the aim point on the RF Icon, and tighten the gimbal clamp to lock this position.

**TIP:** Because of the offset between the scope and rangefinder, the laser will only perfectly align with the aim point at one distance. Set beam position at 50m/yds or further to improve alignment at longer ranges

As shooters, we know that there is nothing worse than being let down by your equipment. We have made every effort to build a rugged, reliable product that will not break under any normal circumstances, and have implemented some of the strictest quality control measures in the industry. However, we know that things can go wrong, and therefore we back our electro-optics with a 3 year warranty.

For full terms and information, visit [element-optics.com/warranty](http://element-optics.com/warranty) or scan the QR code below.



The Element Optics 3 Year Warranty applies to Electro Optics only, and does not cover accessories purchased separately. Theft, loss, deliberate damage and cosmetic damage that does not hinder the operation of the riflescope is not covered. If your product can not be repaired and a replacement model is no longer in production, a model of equal value will be substituted.

# SPEC SHEET

|                                     |                 |             |
|-------------------------------------|-----------------|-------------|
| MAGNIFICATION                       | 7x              |             |
| OPTICAL SYSTEM TYPE                 | PRISMATIC       |             |
| OBJECTIVE LENS DIAMETER             | 50mm            |             |
| EXIT PUPIL                          | 7mm             |             |
| EYE RELIEF                          | 45mm            |             |
| FIELD OF VIEW                       | @100yds: 25.5ft | @100m: 8.8m |
| MINIMUM PARALLAX                    | 6 YDS           | 6 METERS    |
| DIGITAL ELEVATION TRAVEL            | 81 MOA          | 23.5 MRAD   |
| MECHANICAL ELEVATION TRAVEL (MOUNT) | 160 MOA         | 46 MRAD     |
| LENGTH                              | 6.81"           | 173mm       |
| WEIGHT (WITH BATTERY)               | 18.3oz          | 518g        |
| WATERPROOF                          | YES             |             |
| FOGPROOF                            | YES             |             |



@WeAreElementOptics



Element Optics



element\_optics



[www.element-optics.com](http://www.element-optics.com)